

Slubs
Line1op 2019



Linetop
Encimera

Tattoo Oxidum Decor	04
Equinox Grey Natural	10
Statuario Extra White Bookmatch	16
Pietra Grey Polished and Natural	22
St. Vincent Anthracite	30
Calacatta Lincoln	36
Agata Blue	44
Super White	50
Super Black Natural	54
Washbasins	58

Linetop
12 mm

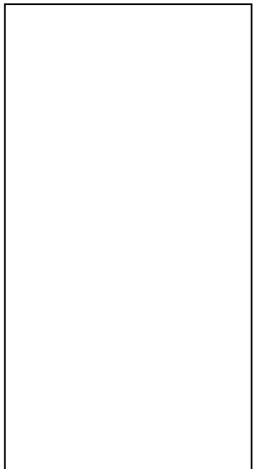

162x324
162 x 324 cm
63.8" x 127.6"

* 162x324 Linetops are in full
size pieces non rectified
* 162x324 Linetops no está
rectificado



Finishes



Polished



Natural





Tattoo

Tattoo
Oxidum
Decor
Natural

Tattoo Oxidum Decor



Linetops 12 mm

Tattoo Oxidum Decor Linetops 162x324 G-3574







Equinox

Equinox
Grey
Natural

Equinox Grey Natural

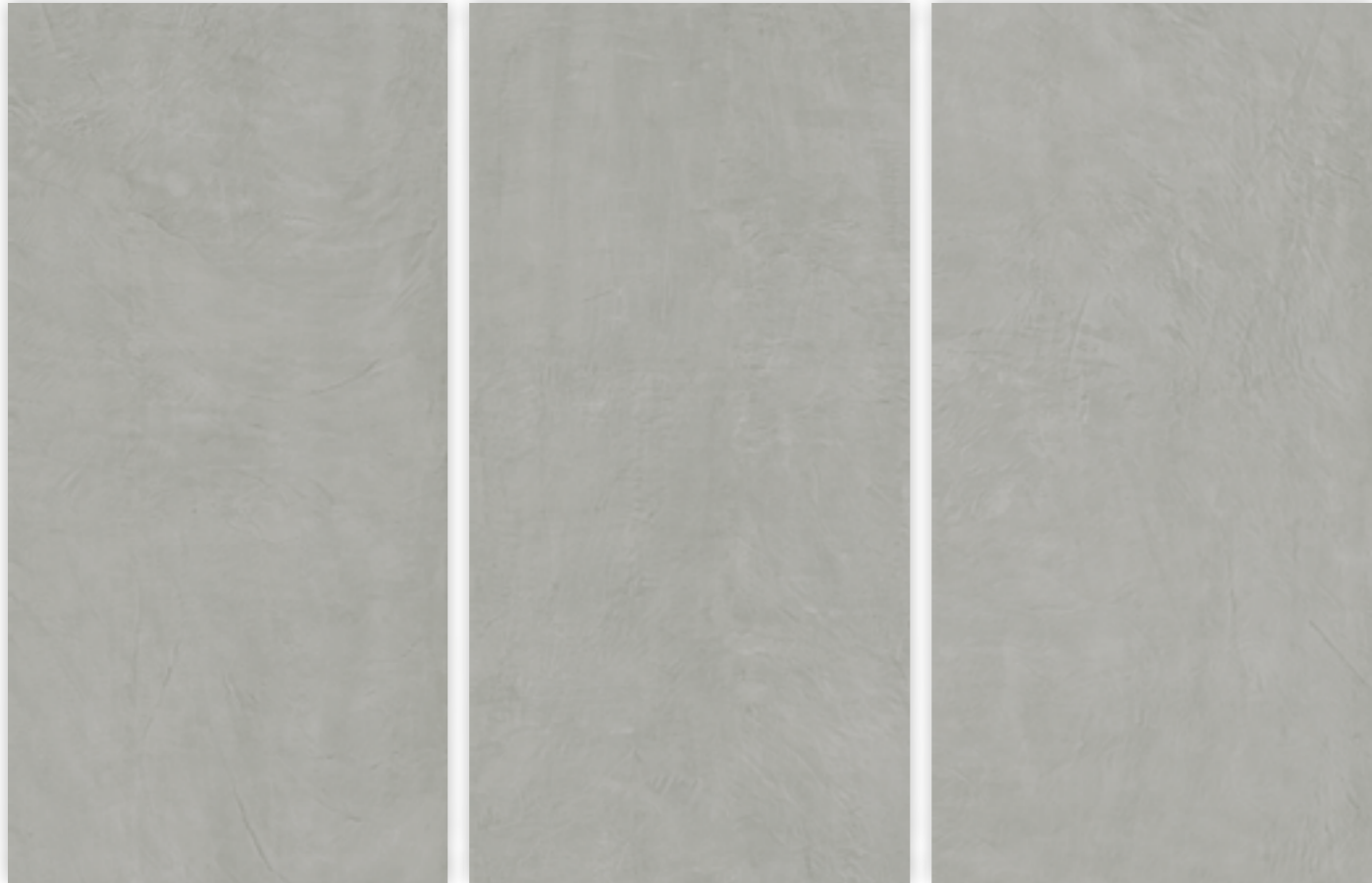

Linetops 12 mm
Equinox Grey Natural Linetops 162x324 G-3520







Statuario

Statuario
Extra White
Natural
&
Polished

Statuario Extra White Bookmatch Polished / Natural



Block A

Block B

Bookmatch

Linetops 12 mm

Statuario Extra White Polished BL.A 162x324* G-3654

Statuario Extra White Polished BL.B 162x324* G-3654

Statuario Extra White Natural BL.A 162x324* G-3620

Statuario Extra White Natural BL.B 162x324* G-3620



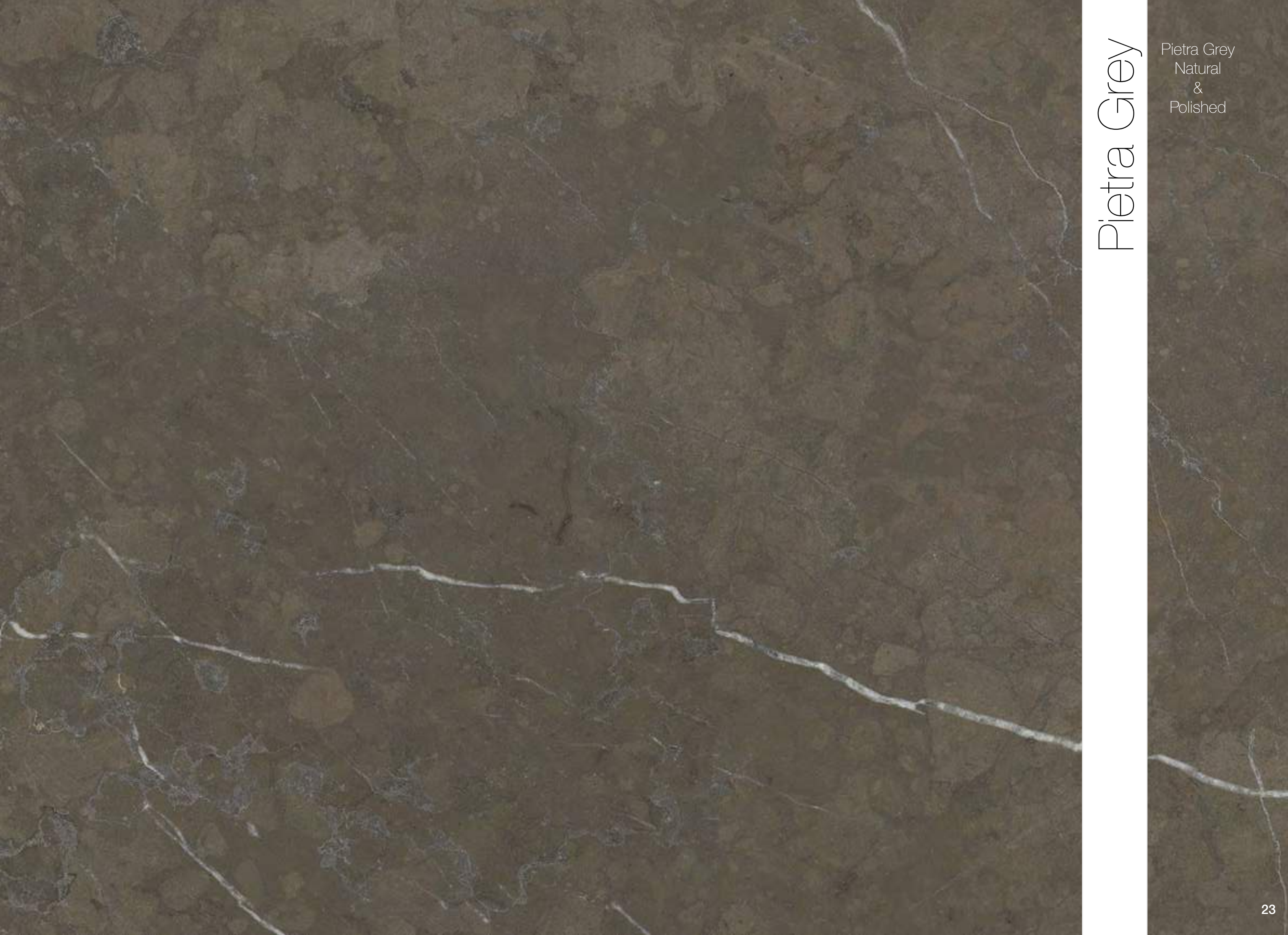

Pietra Grey

Pietra Grey
Natural
&
Polished

Pietra Grey Polished / Natural



Linetops 12 mm
Pietra Grey Polished 162x324 G-3616
Pietra Grey Natural 162x324 G-3590







St. Vincent

St. Vincent Anthracite Polished / Anthracite Natural



Linetops 12 mm
St. Vincent Anthracite Polished 162x324 G-3616
St. Vincent Anthracite Natural 162x324 G-3590







Calacatta Lincoln

Calacatta
Lincoln
Polished
&
Natural

Calacatta Lincoln Polished / Natural







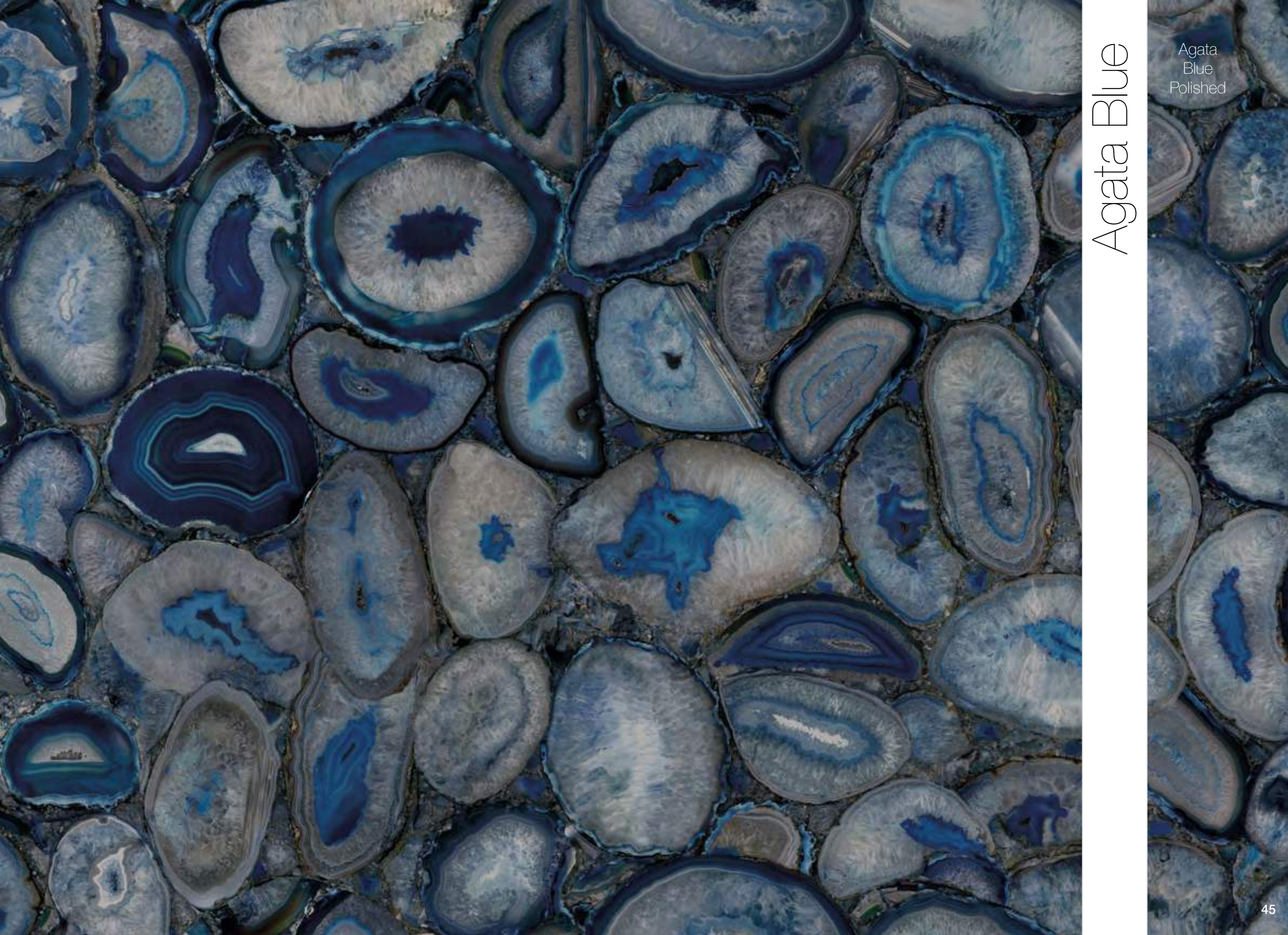

Agata Blue

Agata
Blue
Polished

Agata Blue Polished





Super White

Super White

Linetops

Natural & Polished 12 mm



162x324

162 x 324 cm
63.8" x 127.6"

Linetops 12 mm

Super White Natural 162x324	G-3727
Super White Polished 162x324	G-3779

* 162x324 Linetops are in full size pieces non rectified
* 162x324 Linetops no está rectificando



Super Black

Linetops
Natural 12 mm

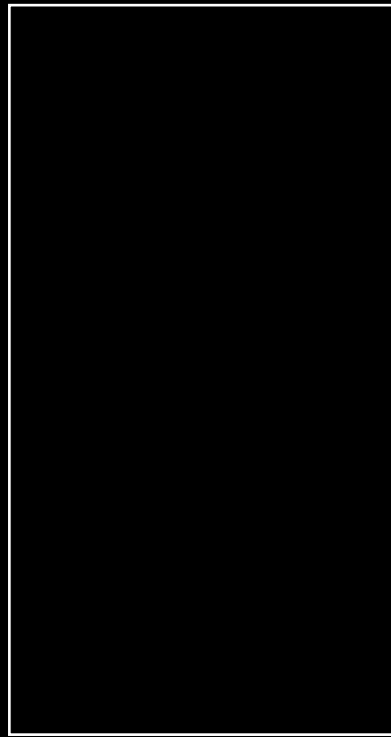

162x324
162 x 324 cm
63.8" x 127.6"

Linetops 12 mm
Super Black Natural 162x324 G-3727



* 162x324 Linetops are in full size pieces non rectified
* 162x324 Linetops no está rectificad

Super Black



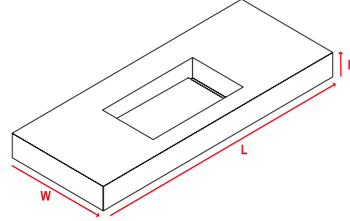

Washbasins - Lavabos

Available in all LINETOPS 12 mm series
 Disponible en todas las series LINETOPS 12 mm.

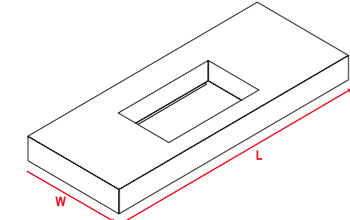

BASIC (all sides drain)
 L 80/120/180 cm x W 45 cm x H 12 cm

L - 80		L - 120		L - 180	
Nat	Pol	Nat	Pol	Nat	Pol
G-2976	G-2982	G-2976	G-2982	G-2980	G-2986

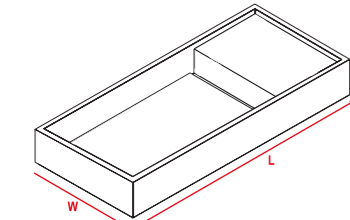

SIMPLE (one side drain)
 L 80/120/180 cm x W 45 cm x H 12 cm

L - 80		L - 120		L - 180	
Nat	Pol	Nat	Pol	Nat	Pol
G-2978	G-2984	G-2978	G-2984	G-2982	G-2988

BLOCK (all sides drain)
 L 80/120/180 cm x W 45 cm x H 12 cm

L - 100		L - 120		L - 180	
Nat	Pol	Nat	Pol	Nat	Pol
G-2980	G-2986	G-2984	G-2990	G-2988	G-2994

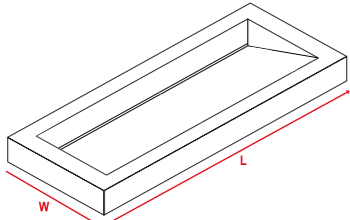



NIAGARA (one side drain)
 L 180 cm x W 50 cm x H 12 cm

L - 180	
Nat	Pol
G-2988	G-2994

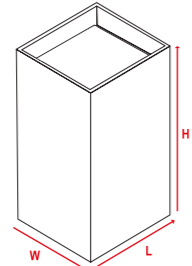

FREE STANDING (all sides drain)
 L 45 cm x W 45 cm x H 90 cm

L - 45	
Nat	Pol
G-2976	G-2982

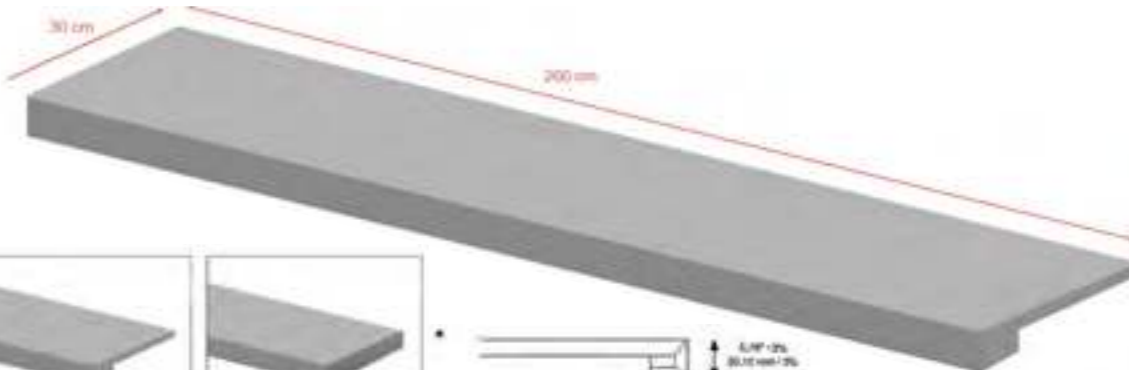

Steps - Peldaños

Steps 260 cm
 Peldaños 260 cm

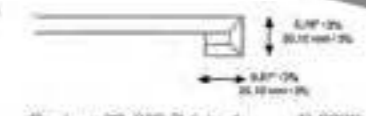
Gradone 30 Gradone 260 Gradone ángulo



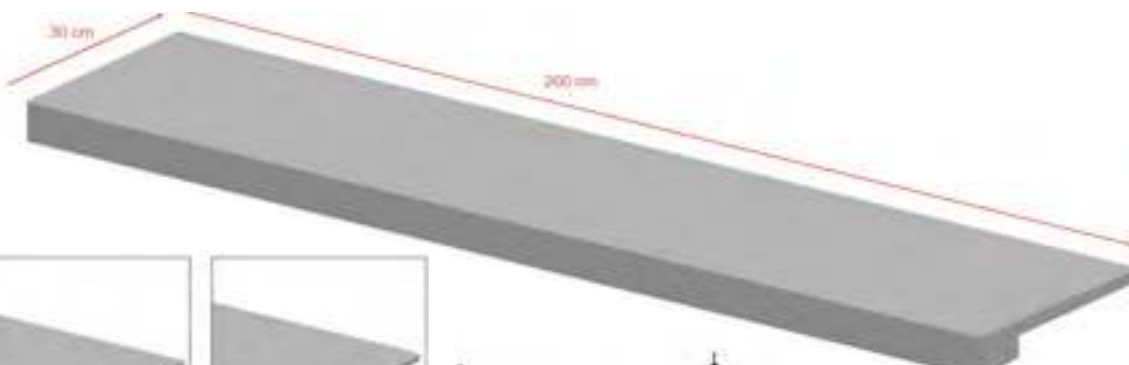

Gradone 30x260 Polished G-2883
 Gradone 30x260 Natural G-2875

Peldaño 30 Peldaño 260 Peldaño ángulo

Peldaño 30x260 Polished G-2889
 Peldaño 30x260 Natural G-2879

Steps 130 cm
 Peldaños 130 cm

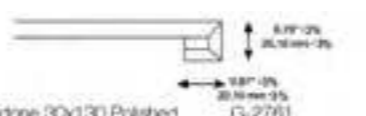
Gradone 30 Gradone 130 Gradone ángulo

Gradone 30x130 Polished G-2781
 Gradone 30x130 Natural G-2741

Peldaño 30x130 Polished G-2877
 Peldaño 30x130 Natural G-2851



Ventilated facades

Fachadas ventiladas

System parts
Partes del sistema

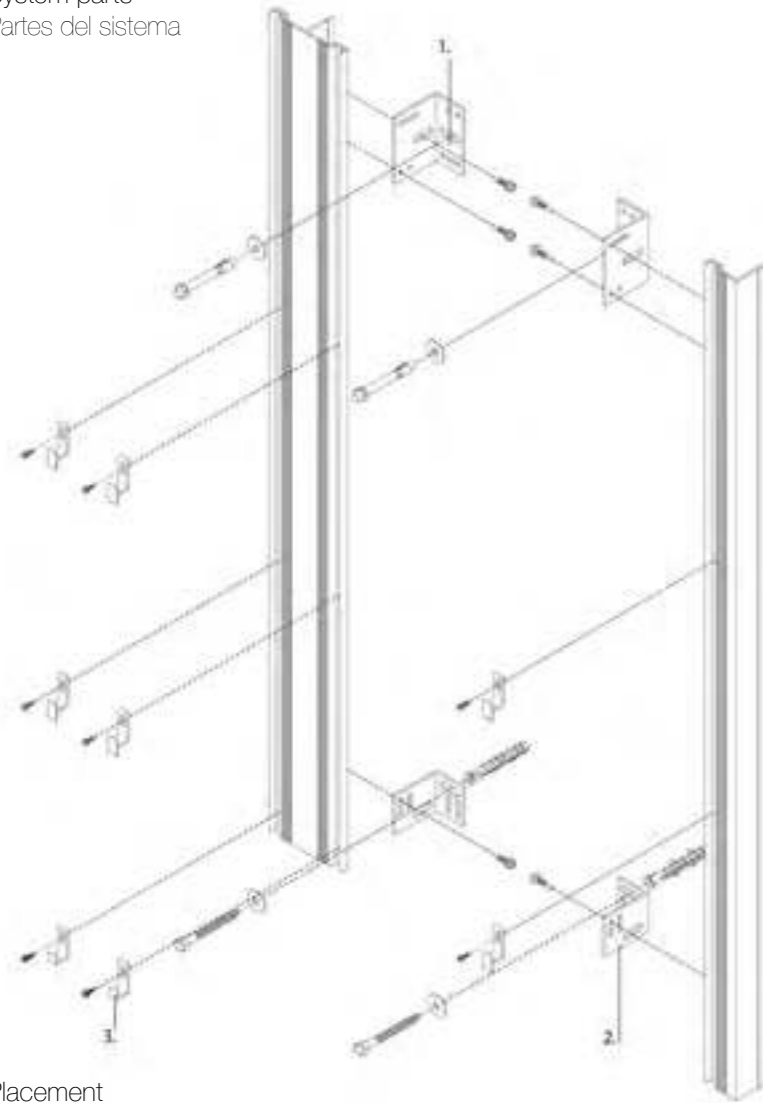

Placement
Colocación del sistema

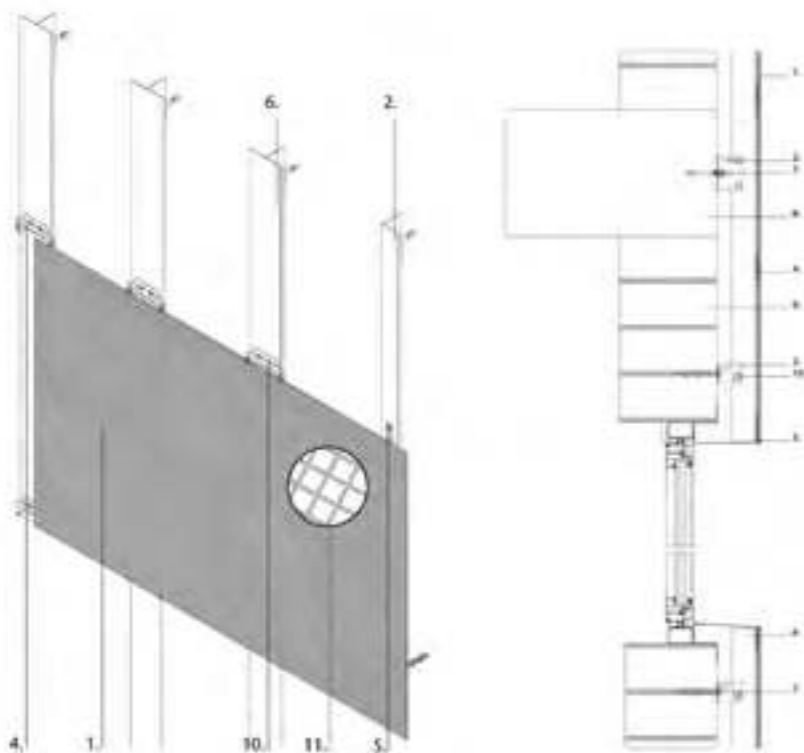

System components
Componentes del sistema



1-Angular load anchors 60-160 mm
Escuadras de carga 60-160 mm



2-Angular support anchors 60-160 mm
Escuadras de apoyo 60-160 mm



3-ALFA fasteners
Grapas ALFA

Visible clip fasteners detail
Detalle de grapas visible



Hidden clip fastener detail
Detalle de grapas invisible



1. Apvisa Slabs 120x260x0,65 cm
2. Loading square (60+40) 80x3 / Escuadra de carga (60+40) 80x3
3. Support bracket (60+40) 46x3 / Escuadra de apoyo (60+40) 46x3
4. Staple Alpha continuation / Grapa ALFA continuación
5. Staple Alpha start-finish / Grapa ALFA inicio-remate
6. Epsilon profile "T 100 60" / Perfil Epsilon "T 100 60"
7. Fixation / Fijación
8. Wrought / Forjado
9. Epsilon Profile "L 50 60" / Perfil Epsilon "L 50 60"
10. Self-drilling 5,5x25 / Autotaladrante 5,5 x 25
11. Detail meshed / Detalle de malla

Handling

Manipulación

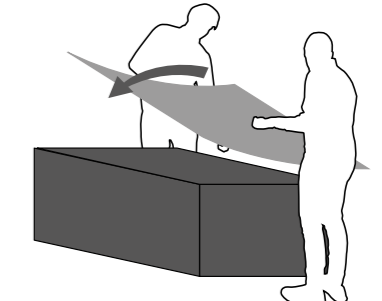
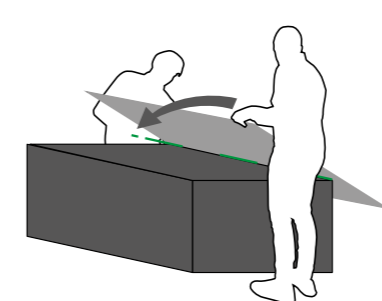
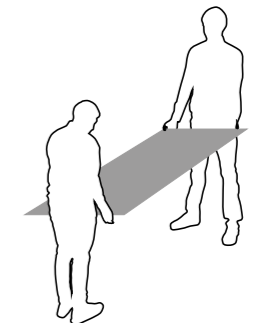
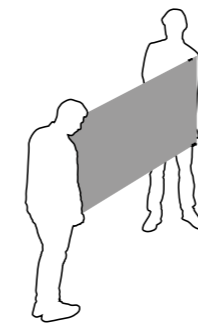
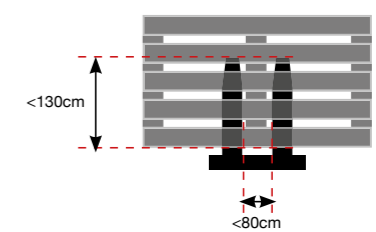
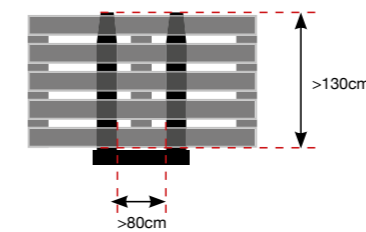
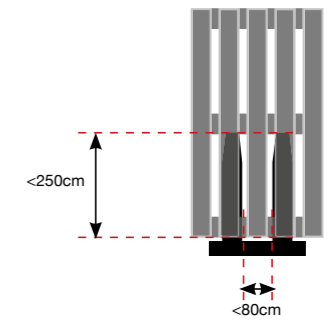
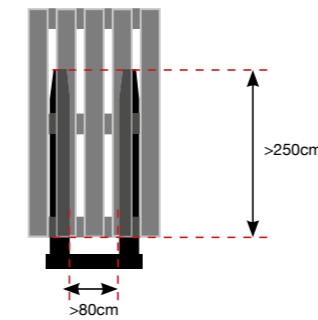
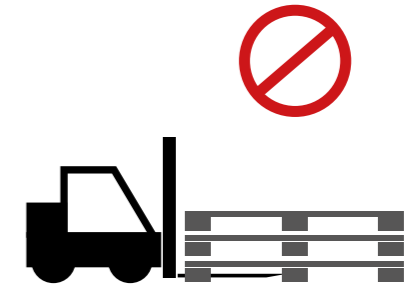

Packing Linetop 12mm

Embalaje para Linetop 12mm



Bundle

Sizes Formatos	Real size Formato real	Bundle sizes Medidas bundle	Pieces Piezas	m ²	SF	Kg/m ²	Total (Kg)
162x324 64"x128"	162x324 63.8"x127.6"	27x324x162 cm - 11" x 128" x 64"	20	104,98	1129,99	32,75	3488 Kg



A-frame / Caballete

Sizes Formatos	A-frame sizes Medidas caballete	Pieces Piezas	m ²	SF	Kg/m ²	Peso Total
162x324 64"x128"	75 x 330 x 200 cm - 30" x 130" x 79"	16	83,98	903,95	32,75	2900 Kg

Packing Slabs 6 mm

Embalaje Slabs 6 mm

A-frame / Caballete

Sizes Formatos	A-frame sizes Medidas caballete	Pieces Piezas	m ²	SF	Kg/m ²	Peso Total
120x260 48"x102"	75 x 270 x 157 cm - 30" x 107" x 62"	40	124,07	1335,48	16,35	2150 Kg

Packing Slabs 6 mm

Embalaje Slabs 6 mm

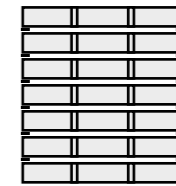

7 levels
7 niveles

Crate / caja madera

Sizes Formatos	Real size Formato real	Crate sizes Medidas de caja	Pieces Piezas	m ²	SF	Kg/m	Total (Kg)
160x320 63"x126"	160x320 62.99"x125.98"	175 x 340 x 38 cm 68.89" x 133.85" x 14.96"	14	71,68	771,56	14,45	1.180 Kg
120x260 48"x102"	129,3x260 46.97"x102.4"	140 x 280 x 27 cm 55" x 110" x 10"	17	52,73	567,59	16,35	926 Kg
60x260 23"x102"	59,55x260 23.45"x102.4"	140 x 280 x 27 cm 55" x 110" x 10"	34	52,64	566,64	16,35	926 Kg
160x160 63"x63"	160x160 62.99"x62.99"	175 x 183 x 41 cm 68.89" x 72.04" x 16.14"	24	61,44	661,34	14,45	975 Kg

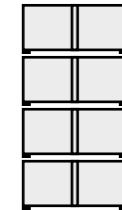

4 levels
4 niveles

Pallet / palet

Sizes Formatos	Real size Formato real	Pallet sizes Medidas de palet	Boxes Cajas	Pieces Piezas	m ²	SF	Kg/m	Total (Kg)
80x160 31.49"x62.99"	80x160 cm 31.49"x62.99"	90 x 175 x 50 cm 35.43" x 68.89" x 19.68"	34	34	43,52	468,44	14,45	700 Kg
120x120 48"x48"	119,3x119,3 cm 46.97"x 46.97"	130 x 130 x 50 cm 51" x 51" x 20"	32	32	45,54	490,23	16,35	793 Kg
60x120 23,62" x 47,24"	59,55x119,3 cm 23.45"x46.97"	120 x 80 x 110 cm 47.24" x 31.49" x 43.30"	30	2	42,63	458,83	17,59	746 Kg
50x100 19,68" x 39,37"	49,75x99,55 cm 19.59"x39.19"	105 x 105 x 62 cm 41.33" x 41.33" x 24.40"	36	1	17,83	191,91	47,64	849,38 Kg
90x90 35,43" x35,43"	89,46x89,46 cm 35.22"x 35.22"	100 x 95 x 60 cm 39.37" x 37.40" x 23,62"	20	2	32,01	344,58	17,07	546 Kg
45x90 17,716" x35,43"	44,63x89,46 cm 17.57"x35.22"	120 x 100 x 60 cm 48" x 39,37" x 23,62"	27	5	53,90	580,18	17,62	950 Kg
60x60 23,62" x 23,62"	59,55x59,55 cm 23.45"x 23.45"	120 x 80 x 80 cm 48" x 31,49" x 31,49"	30	5	53,19	572,56	17,28	920 Kg
30x60 11.81" x 23,62"	29,75x59,55 cm 11.71" x 23.45"	120 x 80 x 80 cm 48" x 31,49" x 31,49"	40	8	56,69	610,22	17,07	968 kg

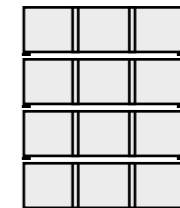

4 levels
4 niveles

30x260 packed with carton box.
30x260 embalado con caja de cartón.

Pallet / palet

Sizes Formatos	Real size Formato real	Pallet sizes Medidas de palet	Boxes Cajas	Pieces Piezas	m ²	SF	Kg/m	Total (Kg)
30x260 11,81"x 102,36"	29,75x260 cm 11.81"x102.4"	75 x 262 x 50 cm 29.52"x103,15"x19.68"	32	64	49,50	49,50	16,35	885,7 Kg
60x260 Decor 23"x102"	59,55x260 23.45"x102.4"	75 x 262 x 50 cm 29.52"x103,15"x19.68"	15	1	23,22	249,98	16,34	444,62 Kg















Anti-Slip Values

Valores antideslizamiento

Reference / Referencia	Values / Valores
Equinox Anthracite	<p>Natural: DIN R10, CLASS B, DCOF >0,42, PTV >36, CLASE 1</p> <p>Satin: DIN R10, DCOF >0,42, CLASE 1</p> <p>Non-Slip: DIN R11, CLASS C, DCOF >0,42, CLASE 3</p>
Equinox Grey	<p>Natural: DIN R10, CLASS B, DCOF >0,42, PTV >36, CLASE 1</p> <p>Satin: DIN R10, DCOF >0,42, CLASE 1</p> <p>Non-Slip: DIN R11, CLASS C, DCOF >0,42, CLASE 3</p> <p>Solid 2 cm: DIN R11, CLASS C, PTV >36, CLASE 3</p>
Equinox White	<p>Natural: DIN R10, CLASS B, DCOF >0,42, PTV >36, CLASE 1</p> <p>Satin: DIN R10, DCOF >0,42, CLASE 1</p>
Instinto taupe	<p>Natural: DIN R10, DCOF >0,42, PTV >36, CLASE 1</p> <p>Lappato & Non-Slip: DIN R10, DCOF >0,42, PTV >36, CLASE 2</p> <p>Solid 2cm: DIN R11, CLASS C, PTV >36, CLASE 3</p> <p>Rescato: DIN R10, DCOF >0,42, PTV >36, CLASE 1</p>
Instinto white	<p>Natural: DIN R10, DCOF >0,42, CLASE 1, PTV >36</p> <p>Lappato: DIN R10, DCOF >0,42, PTV >36, CLASE 2</p> <p>Non-Slip: DIN R10, DCOF >0,42, PTV >36, CLASE 3</p> <p>Rescato: DIN R10, DCOF >0,42, PTV >36, CLASE 1</p>
Junoon Beige	<p>Natural: DIN R10, DCOF >0,42, PTV >36, CLASE 1</p> <p>Solid 2 cm: DIN R11, CLASS C, PTV >36, CLASE 3</p>
Junoon Brown	<p>Natural: DIN R10, DCOF >0,42, PTV >36, CLASE 1</p>

Reference / Referencia	Values / Valores
Junoon Maple	<p>Natural: DIN R10, DCOF >0,42, PTV >36, CLASE 1</p> <p>Solid 2 cm: DIN R11, CLASS C, PTV >36, CLASE 3</p>
Pietra Grey	<p>Natural: DIN R10, DCOF >0,42, PTV >24, CLASE 1</p>
St. Vincent Anthracite	<p>Natural: DIN R10, DCOF >0,42, PTV >36, CLASE 2</p> <p>Solid 2 cm: DIN R11, CLASS C, PTV >36, CLASE 3</p>
Statuario Extra White M	<p>Natural: DIN R9, DCOF >0,42, PTV <24, CLASE 1</p>
Tattoo Black	<p>Decor: DIN R10, DCOF >0,42, PTV >24, CLASE 1</p> <p>Non-Slip: DCOF >0,42, DIN R11, CLASS C, CLASE 3</p> <p>Solid 2 cm: DIN R11, CLASS C, PTV >36, CLASE 3</p>
Tattoo Oxidum	<p>Decor: DIN R10, DCOF >0,42, PTV >24, CLASE 1</p>
Tattoo White	<p>Natural: DIN R10, CLASS B, DCOF >0,42, PTV >36, CLASE 1</p> <p>Satin: DIN R10, DCOF >0,42, CLASE 1</p> <p>Non-Slip: DIN R11, CLASS C, DCOF >0,42, CLASE 3</p>

Polished / Pulido

TECHNICAL CHARACTERISTICS CARACTERÍSTICAS TÉCNICAS	STANDARD TEST METHOD MÉTODO DE LA NORMA	STANDARD PRESCRIBED VALUES VALOR PRESCRITO POR LA NORMA	SLABS VALUE VALOR SLABS
MEASUREMENTS SURFACE APPEARANCE / DIMENSIONES Y ASPECTO SUPERFICIAL			
 NOMINAL THICKNESS/ ESPESOR NOMINAL			6,5mm - 1/4"
 LENGTH AND WIDTH / LONGITUD Y ANCHURA	UNE - EN ISO 10545 - 2	+/- 0.6 % max	+/- 0.1 %
 THICKNESS / ESPESOR	UNE - EN ISO 10545 - 2	+/- 5.0 % max	+/- 2.0 %
 ORTHOGONALITY / ORTOGONALIDAD	UNE - EN ISO 10545 - 2	+/- 0.6 % max	+/- 0.2 %
 SURFACE FLATNESS / PLANITUD DE SUPERFICIE	UNE - EN ISO 10545 - 2	+/- 0.5 % max	+/- 0.2 %
PHYSICAL PROPERTIES / PROPIEDADES FÍSICAS			
 WATER ABSORPTION / ABSORCIÓN DE AGUA	UNE - EN ISO 10545 - 3	< 0.5 %	<0.1 %
 BENDING RESISTANCE / RESISTENCIA A LA FLEXIÓN	UNE - EN ISO 10545 - 4	> 35 N/mm ²	>50 N/mm ²
 BREAKING STRENGTH / FUERZA DE ROTURA	UNE - EN ISO 10545 - 4	> 700 N	>2000 N
 RESISTANCE TO DEEP ABRASION / RESISTENCIA A LA ABRASIÓN PROFUNDA	UNE - EN ISO 10545 - 6	< 175 mm ³	<170mm ³
 TEMPERATURE SHOCK RESISTANCE / RESISTENCIA AL CHOQUE TERMICO	UNE - EN ISO 10545 - 9	NO SURFACE DEFECTS SHOULD BE VISIBLE NO DEBE PRESENTAR DEFECTOS O ROTURAS VISIBLES	Resistant / Resistente
 RESISTANCE TO COLD / RESISTENCIA A LA HELADA	UNE - EN ISO 10545 - 12	NO SURFACE DEFECTS OR CRACKS SHOULD BE VISIBLE NO DEBE PRESENTAR DEFECTOS VISIBLES	ANTI-ICE / Antihielo
 ANTI-SLIP / ANTIDESLIZAMIENTO	DIN 51130	-	-
	DIN 51097	-	-
	UNE - ENV 12633	-	-
	ASTM C 1028-96	-	-
	BS EN 13036-4	-	-
 COLOUR RESISTANCE TO LIGHT / RESISTENCIA DEL COLOR A LA LUZ	DIN 51094	THERE SHOULD BE NO COLOUR VARIATIONS NO DEBE PRESENTAR VARIACIONES DE COLOR	NO ALTERATIONS
CHEMICAL PROPERTIES / PROPIEDADES QUÍMICAS			
 CHEMICAL RESISTANCE / RESISTENCIA QUÍMICA	UNE - EN ISO 10545 - 13	RESISTANCE TO CHEMICAL PRODUCTS	Min. ULB /UHB
 RESISTANCE TO STAINING / RESISTENCIA A LAS MANCHAS	UNE - EN ISO 10545 - 14	>3 RESISTENCIA A PRODUCTOS QUÍMICOS	4

General information / Información general

Recommended information

All products receive a protective coating to prevent possible attacks during their placement in the implementation process at work. This protection should be completely removed resulting in clean material. Please consult our commercial network if you have any questions regarding recommended cleaning for our products.

Información recomendada

Todos los productos llevan una aplicación protectora para evitar posibles agresiones durante su colocación en el proceso de ejecución de la obra. Esta aplicación debe eliminarse completamente para conseguir una limpieza óptima del material. Consulte con nuestra red comercial cualquier duda acerca de las recomendaciones de limpieza de nuestro producto.















Information reommandée

Tous nos produits viennent avec une pellicule protectrice pour éviter les éventuelles agressions lors de la pose du matériel sur chantier. Cette protection doit être complètement éliminée pour obtenir un nettoyage optimum des carreaux. Veuillez consulter auprès de notre réseau commercial pour toute demande sur les recommandation de nettoyage de nos produits.

Empfohlene information

Alle Produkte sind mit einer Schutzschicht versehen um mögliche Angriffe während der Verlegung und Verarbeitung zu vermeiden. Diese Schutzschicht muss vollständig entfernt werden um eine optimale Reinigung des Materials zu erzielen. Bei Fragen zur Reinigungsempfehlung unserer Produkte wenden sie sich bitte an unser Händlernetz.

Natural

TECHNICAL CHARACTERISTICS CARACTERÍSTICAS TÉCNICAS	STANDARD TEST METHOD MÉTODO DE LA NORMA	STANDARD PRESCRIBED VALUES VALOR PRESCRITO POR LA NORMA	SLABS VALUE VALOR SLABS
MEASUREMENTS SURFACE APPEARANCE / DIMENSIONES Y ASPECTO SUPERFICIAL			
 NOMINAL THICKNESS/ ESPESOR NOMINAL			6,5mm - 1/4"
 LENGTH AND WIDTH / LONGITUD Y ANCHURA	UNE - EN ISO 10545 - 2	+/- 0.6 % max	+/- 0.1 %
 THICKNESS / ESPESOR	UNE - EN ISO 10545 - 2	+/- 5.0 % max	+/- 2.0 %
 ORTHOGONALITY / ORTOGONALIDAD	UNE - EN ISO 10545 - 2	+/- 0.6 % max	+/- 0.2 %
 SURFACE FLATNESS / PLANITUD DE SUPERFICIE	UNE - EN ISO 10545 - 2	+/- 0.5 % max	+/- 0.2 %
PHYSICAL PROPERTIES / PROPIEDADES FÍSICAS			
 WATER ABSORPTION / ABSORCIÓN DE AGUA	UNE - EN ISO 10545 - 3	< 0.5 %	<0.1 %
 BENDING RESISTANCE / RESISTENCIA A LA FLEXIÓN	UNE - EN ISO 10545 - 4	> 35 N/mm ²	>50 N/mm ²
 BREAKING STRENGTH / FUERZA DE ROTURA	UNE - EN ISO 10545 - 4	> 700 N	>2000 N
 RESISTANCE TO DEEP ABRASION / RESISTENCIA A LA ABRASIÓN PROFUNDA	UNE - EN ISO 10545 - 6	< 175 mm ³	<170mm ³
 TEMPERATURE SHOCK RESISTANCE / RESISTENCIA AL CHOQUE TERMICO	UNE - EN ISO 10545 - 9	NO SURFACE DEFECTS SHOULD BE VISIBLE NO DEBE PRESENTAR DEFECTOS O ROTURAS VISIBLES	Resistant / Resistente
 RESISTANCE TO COLD / RESISTENCIA A LA HELADA	UNE - EN ISO 10545 - 12	NO SURFACE DEFECTS OR CRACKS SHOULD BE VISIBLE NO DEBE PRESENTAR DEFECTOS VISIBLES	ANTI-ICE / Antihielo
 ANTI-SLIP / ANTIDESLIZAMIENTO	DIN 51130	-	See table / Ver tabla*
	DIN 51097	-	-
	UNE - ENV 12633	-	-
	ANSI A137.1 S-9-6-1	-	>0,42
	BS EN 13036-4	-	-
 COLOUR RESISTANCE TO LIGHT / RESISTENCIA DEL COLOR A LA LUZ	DIN 51094	THERE SHOULD BE NO COLOUR VARIATIONS NO DEBE PRESENTAR VARIACIONES DE COLOR	NO ALTERATIONS
CHEMICAL PROPERTIES / PROPIEDADES QUÍMICAS			
 CHEMICAL RESISTANCE / RESISTENCIA QUÍMICA	UNE - EN ISO 10545 - 13	RESISTANCE TO CHEMICAL PRODUCTS	Min. ULB /UHB
 RESISTANCE TO STAINING / RESISTENCIA A LAS MANCHAS	UNE - EN ISO 10545 - 14	>3 RESISTENCIA A PRODUCTOS QUÍMICOS	4

*See Anti-Slip Values table - pages 114-115

*Ver tabla de valores Anti-Slip - páginas 114-115

Tests for polished finish characteristics done in Statuario White Polished 120x260. Average test result value on March 2017. Consult specific product test result value before supplying.

Pruebas para las características del acabado pulido realizadas sobre el producto Statuario White Polished 120x260. Valor de media a fecha de Marzo 2017. Consultar valor de un producto específico antes del suministro.

Tests for natural finish characteristics done in Tattoo Oxidum Decor 120x260. Average test result value on March 2017. Consult specific product test result value before supplying.

Pruebas para las características del acabado natural realizadas sobre el producto Tattoo Oxidum Decor 120x260. Valor de media a fecha de Marzo 2017. Consultar valor de un producto específico antes del suministro.

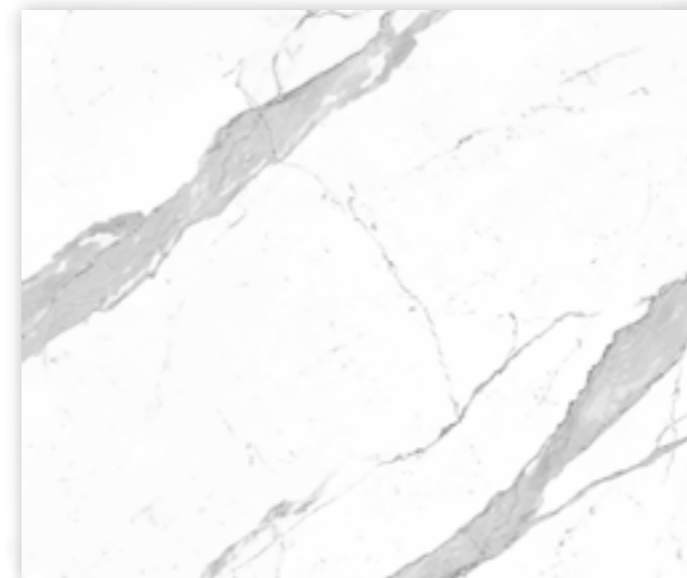

Statuario White Polished



Tattoo Oxidum Decor

Cleaning & maintenance

Eng

The first cleaning "after installation".

The most important cleaning operation is performed immediately after laying the tiles. This involves the complete removal of residues and dirt from the tile placement. An inadequate or late removal of this waste can create a cementitious layer on the tile capable of absorbing all forms of dirt. This may give the impression that the tile gets dirty when the actual problem resides in the surface film of dirt which was not removed immediately after laying.

Once the grouting of the tiles is finished, it is important, while the grout is still wet, to carefully remove any excess material immediately. This can be done using a sponge and plenty of clean water, repeating this as many times as necessary.

Do not perform the cleaning with metal tools, scrapers or abrasive pads. For stubborn stains, clean with alcohol and lukewarm water and rub with a clean cloth. If they do not disappear, check with the relevant technical department.

Once the above mentioned washing is done, another washing should be carried out using basic or alkaline degreasing agents, as acid washing can leave stickiness on the pavement which could help retain dirt. In areas where water is calcareous, it is convenient to dry the surface, in order to prevent the deposition of carbonates which will reduce the surfaces' gleam.

Regular maintenance

Many available cleaning products for general use can be used with our products. For daily cleaning, one can use detergents or degreasing products diluted in warm water, following each product's instructions.

It is important that the cleaner does not have oil, animal fat, or soap base. These components may leave an invisible residue whilst absorbing dirt (lime stratifications detergent or residues). It is also important that the tile receives a thorough rinsing with clean water after the cleaning process is complete.

The low water absorption and high standards met by all porcelain tiles ensure a product which is easy to maintain. Our products do not require the use of sealants or waxes. These superficial coatings can really affect the performance of the tile in a negative manner.

It is important to note that hydrofluoric acid (HF) and derivatives can irreparably damage the tile.

The general steps for regular cleaning of our ceramic products can be summarized as follows:

- Remove any solid or liquid waste from the tile, sweeping with a soft bristle broom or vacuuming.

- Clean up liquid spills as soon as possible with lukewarm water.

- Apply the recommended amount and dilution of the cleaner for the tile (follow the cleaner manufacturer's instructions). The wiper must remain in the tile a minimum period of 5 minutes.

- For unpolished tiles, scrub with a nylon sponge or soft bristle brush. A floor machine equipped with a nylon pad or bristle brush can be used for heavily soiled surfaces. For polished tiles, clean with a nonabrasive cloth.

- Remove the dirty cleaning solution and water with a vacuum cleaner or cloth. Rinse the porcelain tile with clean water and remove again with a vacuum cleaner, mop or towel. It is absolutely essential that all detergent residues are removed completely from the tile. Any remaining detergent that dries on the tiles surface can form a coating that can trap dirt and be very difficult to remove. The tile should be rinsed several times to remove all detergent residues.

During use, the cleaning of the tiles should be similar to window cleaning. Ammonia and even bleach type products can be employed, but both must be diluted in water.

In case of special stains and/or particularly resistant, it is advisable to use specific detergents according to the cleaners' manufacturer. Do not forget that removing any type of stain is easier when it is still fresh.

It is important to always do a pre-test the detergent products result on a small sample of the porcelain.

Limpieza y mantenimiento

Esp

La primera limpieza "después de la colocación"

La operación de limpieza más importante se lleva a cabo inmediatamente "después de la colocación de la baldosa". Esto implica la eliminación completa de los residuos de lechada y de la suciedad de la colocación de las propias baldosas. Una eliminación inadecuada o tardía de estos residuos puede crear sobre la baldosa una película cementosa capaz de absorber toda forma de suciedad, dando la impresión que se ensucia la baldosa, cuando el problema está en la película superficial de suciedad.

Una vez efectuado el rejuntado de las baldosas, es importante cuando el material de rejuntado todavía está fresco, eliminar el material sobrante cuidadosa e inmediatamente, utilizando para ello una esponja y agua limpia abundante, repitiendo esta operación tantas veces como sea necesario.

No debe realizarse la limpieza del material con espátulas metálicas ni estropajos abrasivos. En el caso de manchas resistentes, limpiar con alcohol y agua caliente y frotar con un paño limpio. Si no desaparecen, consultar con el departamento técnico correspondiente.

Una vez efectuado el lavado mencionado arriba, deberá efectuarse un lavado básico o alcalino utilizando detergentes desengrasantes, ya que el lavado ácido puede dejar una untuosidad sobre el pavimento que podría contribuir a retener la suciedad. En aquellas zonas donde el agua sea calcárea conviene secar la superficie para evitar la deposición de carbonatos que disminuyen el brillo superficial.

Mantenimiento regular

Muchos productos de limpieza de uso general que están disponibles son aceptables para el uso en nuestros productos. Se puede emplear para la limpieza diaria detergentes o desengrasantes diluidos en agua caliente, según indicaciones del envase del limpiador. Es importante que el limpiador no tenga base de aceite, grasa animal, o jabón. Estos componentes pueden dejar un residuo invisible al atrapar la suciedad (estratificaciones de cal de detergente o residuos de suciedad). También es importante que la baldosa reciba un enjuague a fondo con agua limpia después que el proceso de limpieza se haya completado.

La densidad inherente y baja absorción de agua de todos los productos aseguran un producto que es fácil de mantener.

No requieren el uso de selladores o ceras. Estos recubrimientos superficiales pueden realmente afectar negativamente el rendimiento de la baldosa.

Es muy importante tener en cuenta que el ácido Fluorhídrico (HF) y derivados pueden dañar irremediablemente la baldosa.

Los pasos generales de limpieza regular para nuestros productos cerámicos se pueden resumir del siguiente modo:

- Retirar cualquier residuo sólido o líquido de la baldosa, barriendo con una escoba de cerdas suaves o pasar la aspiradora.

- Limpiar los derrames líquidos tan pronto como sea posible.

- Aplicar la cantidad y dilución del limpiador recomendadas para la baldosa (ver indicaciones del fabricante del limpiador). El limpiador deberá permanecer en la baldosa un periodo mínimo de tiempo de 5 minutos.

- Para baldosas sin pulir, frotar con una esponja de nylon o un cepillo de cerdas suaves. Para superficies muy sucias puede usarse una máquina de piso equipado con una almohadilla de nylon o con un cepillo de cerdas. Para baldosas pulidas, limpie con un trapo no abrasivo o un paño.

- Retirar la solución de limpieza sucia y el agua con una aspiradora o un trapo. Enjuague la pieza con agua limpia y retire de nuevo con una aspiradora, fregona, o una toalla. Es absolutamente esencial para todos los residuos de detergente que se eliminen por completo de la baldosa. Cualquier resto de detergente que se seque sobre la baldosa puede formar un recubrimiento que puede atrapar la suciedad y será muy difícil de eliminar. La baldosa debe enjuagarse varias veces para eliminar todos los residuos de detergente.

Durante su uso, la limpieza de la baldosa debe hacerse de forma similar a la limpieza de cristales. Se puede emplear productos de tipo amoniacal e incluso lejía, ambos diluidos en agua.

En caso de manchas particulares y/o especialmente resistentes, es aconsejable usar detergentes específicos según especificaciones del fabricante del limpiador. No hay que olvidar que la eliminación de cualquier tipo de mancha resulta más fácil cuando ésta todavía está fresca.

Es importante hacer siempre una prueba previa antes de usar los productos detergentes.



slabs

APAVISA

www.apavisa.com

Ctra. Castellón – San Juan de Moró, hm.7,5 - 12130 SAN JUAN DE MORÓ (Castellón) Spain
Tel. +34 964 701 120 - Export Fax +34 964 701 067 - Fax Nacional 964 701 195 - info@apavisa.com